

This report was prepared as an account of work sponsored by the United States Government. Neither the United States nor the United States Atomic Energy Commission, nor any of their employees, nor any of their contractors, subcontractors, or their employees, makes any warranty, express or implied, or assumes any legal liability or responsibility for the accuracy, completeness or usefulness of any information, apparatus, product or process disclosed, or represents that its use would not infringe privately owned rights.

## MODERN CONTROL TECHNOLOGY WITH MODEL T COMPUTERS \*

James R. Guggemos, Donald J. Rondeau

Lawrence Berkeley Laboratory, University of California

Berkeley, California

In 1968, it was decided to convert one of the Bevatron control systems to a small computer based digital control system. The External Proton Beam was to be expanded from 15 to 64 magnets which would make the analog system in use very cumbersome. A PDP-8 with a tape transport was available and a system was designed and built to control up to 64 pulsed magnets. A 6 megaword disc was soon added to the system. When the system was operational, a second PDP-8 was added to be utilized as a backup computer.

The next step was to start a system to control the pulsing of the Bevatron main guide field. A third PDP-8 was purchased and the pulsing system was developed and put into operation.

We now had an accelerator with the guide field precision of 1 part in 30000 and an extraction magnet system with the resolution of 1 part in 4000 which made for very stable operation. We also had the only accelerator in the world with a major part of its control systems being controlled by computers.

The last system to be developed was the rf control system. The system used a 12-bit 8 K external memory to store the correction curve to control the beam during acceleration. The system also can close the loop radially on the accelerating beam. A fourth PDP-8 was utilized for this system. Later the external memory was replaced by a 16-bit 32 K memory to store the entire frequency curve required to accelerate beam in the Bevatron.

At this time, a second 6 megaword disc was added to the system and two more PDP-8's were purchased to be used as the human interface to the data stored on the disc by the control computers and for development and experimenter support.

As needed, overlays were added to the control computers and now they have approximately 2 K of overlays each.

With the advent of the new 750 keV ion source, 50 MeV linac, 50 MeV transport line, and Bevalac transfer line, it was decided to procure three more PDP-8's to control and monitor these systems. The development of these systems is now in progress and by February 1974 we will have a 9 PDP-8 (4 K each) multiprocessor system with common bulk storage operating the Bevatron and Bevalac systems.

\* This work performed under the auspices of the Atomic Energy Commission.

WASTED

# Lawrence Berkeley National Laboratory

## Recent Work

### Title

MODERN CONTROL TECHNOLOGY WITH MODEL T COMPUTERS

### Permalink

<https://escholarship.org/uc/item/3f64v8x1>

### Authors

Guggemos, James R.

Rondeau, Donald J.

### Publication Date

1973-12-01

Presented at the Digital Equipment  
Computer Users' Society Symposium,  
San Francisco, California,  
December 27-30, 1973

LBL-2136 Rev.  
c.1

MODERN CONTROL TECHNOLOGY  
WITH MODEL T COMPUTERS

RECEIVED  
LAWRENCE  
RADIATION LABORATORY  
JAN 25 1974  
LIBRARY AND  
DOCUMENTS SECTION

James R. Guggemos and Donald J. Rondeau

December 1973

Prepared for the U. S. Atomic Energy Commission  
under Contract W-7405-ENG-48

**For Reference**

Not to be taken from this room

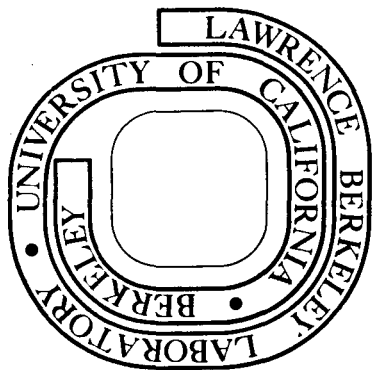

LBL-2136 Rev.  
c.1

## **DISCLAIMER**

This document was prepared as an account of work sponsored by the United States Government. While this document is believed to contain correct information, neither the United States Government nor any agency thereof, nor the Regents of the University of California, nor any of their employees, makes any warranty, express or implied, or assumes any legal responsibility for the accuracy, completeness, or usefulness of any information, apparatus, product, or process disclosed, or represents that its use would not infringe privately owned rights. Reference herein to any specific commercial product, process, or service by its trade name, trademark, manufacturer, or otherwise, does not necessarily constitute or imply its endorsement, recommendation, or favoring by the United States Government or any agency thereof, or the Regents of the University of California. The views and opinions of authors expressed herein do not necessarily state or reflect those of the United States Government or any agency thereof or the Regents of the University of California.

## MODERN CONTROL TECHNOLOGY WITH MODEL T COMPUTERS\*

James R. Guggemos, Donald J. Rendeau  
Lawrence Berkeley Laboratory, University of California  
Berkeley, California

### ABSTRACT

Since its inception, the Bevatron has been an analog controlled machine. In 1968, it was decided to convert one of the control systems to a small-computer based digital control system. The External Proton Beam was to be expanded and existing analog controls were not capable of expansion. In 1970 and 1971, the Guide Field and rf acceleration systems were brought into the digital realm. This paper discusses these systems, their development and expansion and the new systems now under development.

### EXISTING PDP-8 SYSTEM

The existing PDP-8 system (Fig.3) consists of nine PDP-8's, each with 4k of memory, power fail, and EAE options. The three operational (A,B,C) processors are utilized to control their respective systems, without any non-processor oriented back-up. If the processor is stopped, that part of the accelerator ceases to function and particles are not delivered to the experimenter. These three systems are backed up by the D processor with an eleven cable changeover. With a total of ten years of on-line processor time, we have less than 30 hours of Bevatron down time due to processor failure.

The E processor is used to communicate with the magnetic tape for assembly tapes from the LBL CDC 7600 and for DMA bulk storage access to the G, H, and I processors until the new bulk storage interface is completed.

All programs utilize absolute code with absolute overlays where needed. All operating systems are foreground/background (interrupt on/interrupt off) orientated with foreground code resident at all times. The background code, mostly human interface, is overlaid as required. The average amount of overlays required is 16 pages. Processors A through D each have a 12-bit pulse interrupt system attached for Bevatron timing pulses. Bulk storage is by way of one 524kwd disc.

### External Proton Beam

When the External Proton Beam was to be expanded from 15 to 64 magnets (Fig. 8), it was obvious that the existing analog system would be inadequate. With four parameters per magnet, the mind envisions a control panel with 256 unreadable knobs. With the further constraint of quick beam momentum changes, the presetting of up to 256 knobs to arrive at a new operating point was an operationally insurmountable problem.

It was decided to devise a small-computer based system to control and monitor the magnets with good resolution, accuracy, and a minimum delay for major changes of parameters.

Three parallel, 64-word, DMA channels were designed and built to handle the I/O for this

system. The digital transmission channel outputs the magnet control words through a parallel demultiplexer to the individual power supplies where a 12-bit DAC converts the word to an analog control signal. The digital input channel brings in chain status and operator controller status. The analog input channel uses a multiplexer and 12-bit ADC to convert the magnet current monitoring for operator information and display. The update time for all magnets is about 6 msec, which is the control word calculation time.

This system uses two operator controllers (Fig. 5), a storage scope, and teletype for human interface. System retuning time due to momentum changes is reduced by bulk storage of the magnet control parameters.

### Guide Field Control

The Bevatron Guide Field Control System provides five basic features to simplify the control of magnet pulsing; (1) an input procedure that allows an operator to easily define various Bevatron pulse profiles, (2) the ability to analyze the power supply response to any pulse profile prior to pulsing the magnet, (3) a method of selecting and switching to a new operational mode, (4) the ability to analyze the power supply response to the operational mode, (5) a real-time closed-loop computer control for establishing the magnetic field at beam spill time to an accuracy of 1 part in 15,000 gauss.

The Bevatron Guide Field Power Supply includes two 3600 horsepower induction motors, two 70 ton flywheels and two motor generators. The generator output is rectified in eight high voltage ignitron cubicles with a maximum rating of 15,000 volts at 8500 amps with stored energy in the magnet peaking at 78 megajoules.

The Guide Field Computer Control System can set up, predict, control and monitor all necessary parameters to control the guide field to one part in 15,000. Human interface to these parameters is via teletype with bulk storage memory of the various parameter set-ups.

\* Work performed under the auspices of the Atomic Energy Commission.

## RF Acceleration System

The historic rf system used a ferrite core saturated with a current proportional to the magnetic guide field. This core was also the magnetic material for the variable inductance of the LC tank circuit in the Master Oscillator which then produced the needed 500kHz to 2.5MHz frequency curve. At best, this system gave a 95% approximation of the required curve and additional analog correction devices were necessary.

With the advent of accelerating particles other than protons, a more versatile and stable device was required. A new system was developed which allows easier change over to heavy ions and more accurate control. The old Master Oscillator was replaced by a voltage controlled oscillator (VCO). The control voltage supplied to the VCO is developed by a 16-bit digital to analog converter (DAC). A new digital word is sent to the DAC at each 1 gauss increment of the guide field.

A plot of frequency versus field is precalculated and stored in one half of a 32k by 16-bit core memory. Each memory address corresponds to a particular guide field value. The data stored at that address will be the value of the desired frequency.

$$F = \frac{c}{(2\pi R_0 + 4S) \left[ + \left( \frac{m_0 c^2}{eBR_0} \right)^2 \right]^{1/2}}$$

- F = frequency in Hz
- c = speed of light
- R<sub>0</sub> = radius of Bevatron
- S = length of straight section in Bevatron
- m = mass of particles
- e = electron charge
- B = field in Webers/M<sup>2</sup> (Tesla)

The Bevatron guide field changes at the rate of 10 G/ms at injection with a corresponding 1.2kHz change in rf frequency. The range of frequency to be covered is 120kHz to 2.5MHz. The implication is that the frequency has to be controlled to one part in 60,000, which dictated a 16-bit digital system with a corresponding 40Hz/bit.

The radial feedback is of primary importance to operation at the Bevatron. The signals from the radius electrodes (Fig. 9) are brought into the processor DMA every update cycle (1 ms). The radius is then calculated and put into the feedback calculation and rolled off through a software single pole RC network. The radial feedback (12 bits) is added to the 16-bits of frequency data before the data is sent to the 16-bit DAC. This radius error signal can be written into part of the 32k memory and then played back to get an effective increase in loop gain.

Another important feature is remembering the radial error signal used in heavy ion acceleration. When heavy ion particles of insufficient intensity (less than 10<sup>7</sup>) to be picked up by the radial electrodes are to be accelerated, another heavy ion of similar e/m ratio, but with higher intensity, is accelerated and the radial error signal is remembered. The remembered error signal is played back for the low intensity ions and acceleration is achieved. The playback concept proved to be a valuable one

in the successful acceleration of carbon, oxygen, nitrogen and neon at the Bevatron.

## FUTURE PDP-8 SYSTEM

The future PDP-8 system (Fig. 4), now under construction, will utilize two 524kwd discs interfaced through a cache memory buffer system with 16 ports. When a processor requires data from the disc, it requests it by disc number and track sector address. The 128 word cache is loaded with the data from the disc and causes a done interrupt to the processor. The converse is to load the cache from the processor, transmit the disc number and track sector address and a done interrupt will occur when the data is transferred to the disc. This system will allow consecutive sector reads or writes from different processors.

A new 64 channel interrupt system will also be implemented which will have 40 channels of common interrupts and 24 channels of system orientated interrupts for each processor. Each processor has 16 possible interrupts obtained by renaming any of the 64 interrupts with its own name (0-17<sub>g</sub>). When an interrupt occurs, the processor will ACC transfer the interrupt name and process this name through its interrupt jump list and service the interrupt. The interrupt recognition time and jump to service routine time is about 30 μsecs.

## 50 MeV Injector

The new 50 MeV injector to be used for the Bevatron will use a complete digital control and monitoring system, centered around three PDP-8's.

## Chains

The chains for the injector is a parallel indicating, current source and logic level system. All chains are monitored by a chain-scanner. This device collects the status of all chains. The technician can examine the status of any chain by selecting the desired chain with a set of thumbwheel switches. There are eight chains per bin, ten bins per rack, and eight racks total.

The status of all the parameters are sequentially monitored once every 15 ms by the chain-scanner. The output of the scanner is also sent via PDM to the computer where an operator can examine any of the chains that have a change in status, ultimately, displaying the actual parameter that has been changed.

750 keV Ion Gun - The Ion Source terminal contains seven power supplies that have to be controlled from a remote position. The control of the power supplies is in two stages; (1) a course control obtained with a stepping motor and a Variac and (2) a fine control using a 12-bit DAC.

A PDP-8 computer is used for control and monitoring by a PDM optical data link between the computer and terminal, which is at 750 kV. In the terminal, the data is received and transmitted by a 32-channel multiplexer and de-multiplexer. The multiplexer-demultiplexer handles all data communications between the computer, the semi-conductor memory and the power supplies.

The control system is centered around a high speed calculator and a 1k by 16-bit semi-conductor memory. All data is stored in the semi-conductor memory and multiplexed in and out to whichever device needs has data. The calculator communicates only with the semi-conductor memory as does any other device. The calculator will determine the control word using a micro-processor which is a 256 word 8-bit field programmable read only memory. A new control word is calculated for all channels once every 2 ms.

Beam Transport System - The Beam Transport System for the 50 MeV injector will have 50 dc magnets all operating under closed loop control through the processor. This system will also have nine segment faraday cups to determine horizontal and vertical position. The processor will read the cup data and create a horizontal and vertical representation of the beam position on a storage scope for operator information. Future plans call for the processor to close the loop on beam position using the nine segment cups.

#### BEVALAC

The Bevalac is the utilization of the output of the Super Heavy Ion Linear Accelerator to feed the Bevatron heavy ion particles that the Bevatron's injection system cannot create. This system consists of 26 dc magnets connecting the Super HILAC with the 50 MeV transport line (Fig. 7). These magnets and four - 9 segment cups will be controlled and monitored by the processor controlling the 50 MeV transport system.

The Bevalac project poses some problems that can be easily handled by the versatility of the existing PDP-8 system at the Bevatron. One of the proposed modes of operation is to operate the

Bevatron with protons in a somewhat normal mode with heavy ion pulses interleaved into the proton operation in some ratio. This mode will demand that the External Proton Beam, Guide Field, rf System and 50 MeV transport system processors will have to switch modes of operation in a few hundred milliseconds. This mode change will be implemented by bringing in from bulk storage the necessary parameter changes to operate. The flexibility of the processor system in this context is only limited by the physical limitations of the Bevatron hardware itself and should prove an interesting goal to achieve.

#### SUMMARY

The Bevatron Control System has been created to allow the Bevatron to expand in its operational concept. The ability of the system to evolve without interrupting operation of the Bevatron is of primary importance. The concept of adding another processor, if the task requires it, is a valuable one. The concept of a small processor doing a dedicated task is gaining ground in the control community.

The Bevatron was the first accelerator to be operated under complete processor control and processor control will be extended anywhere that it can help us achieve our goals.

The first rule of processor control one has to remember at all times in the development of this type of system is; "The processor will make every attempt to destroy the hardware and humans subject to its control." Hardware must be designed in such a manner that the software cannot in any way cause the destruction or damage to men and equipment.

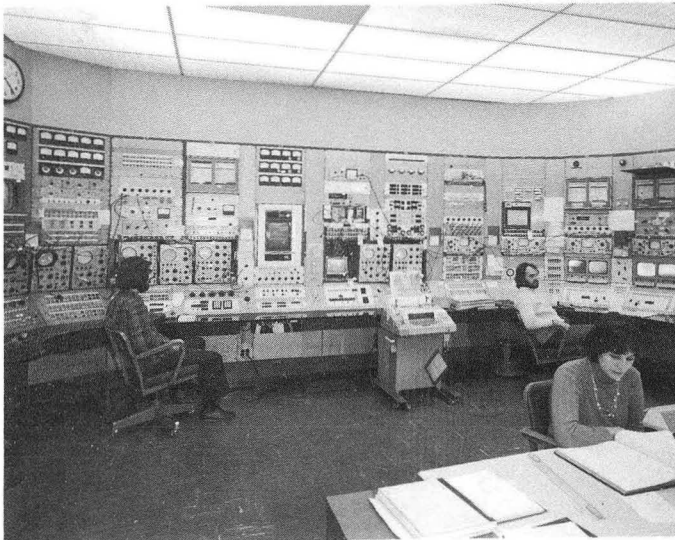

Fig. 1 - Bevatron Main Control Room

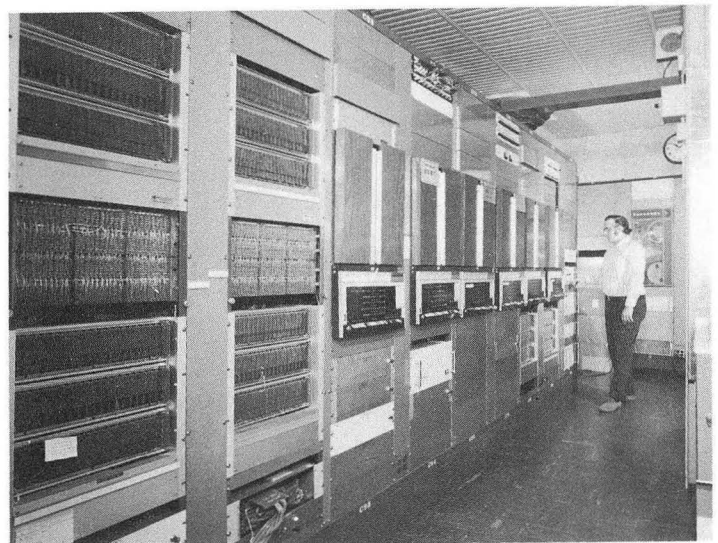
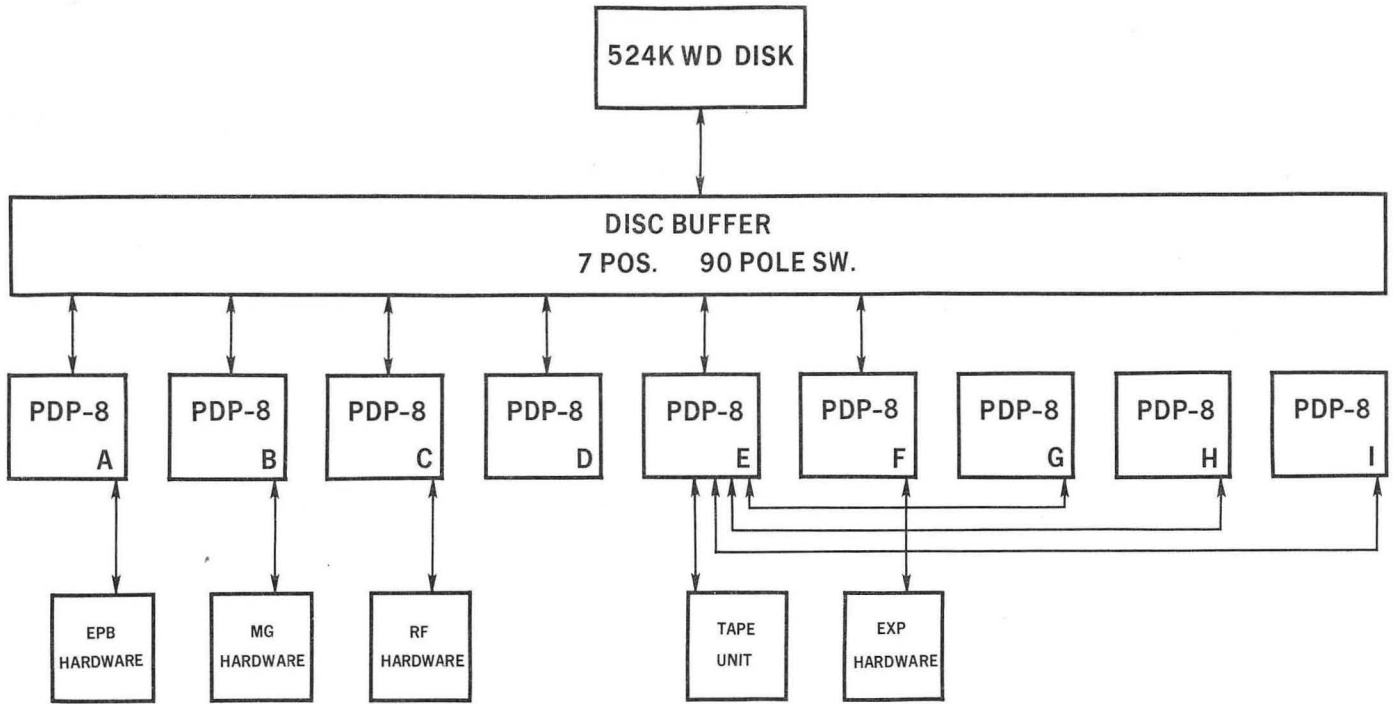
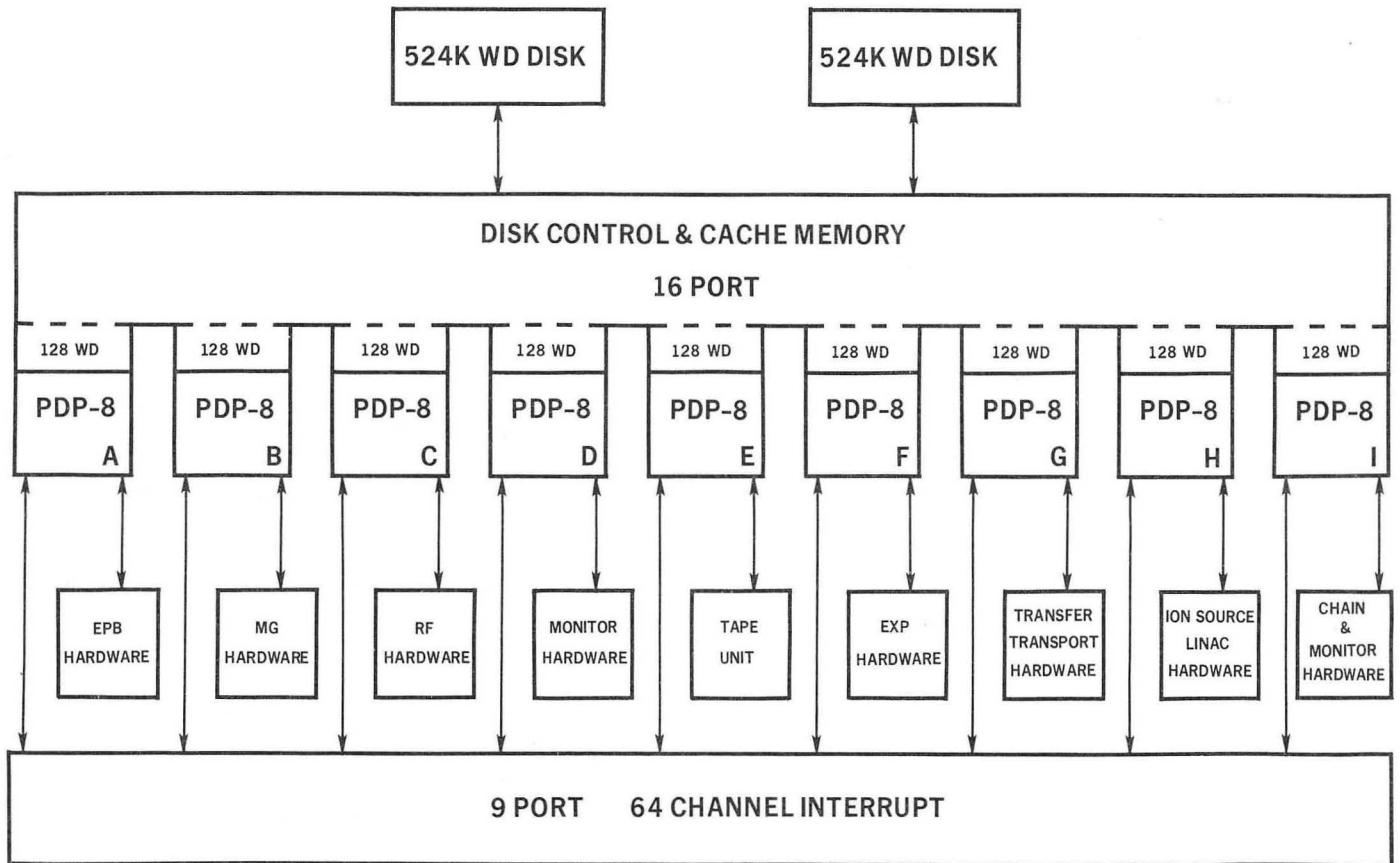

Fig. 2 - Computer Room



XBL 7311-1489

Fig. 3 - Existing System Block Diagram



XBL 7311-1490

Fig. 4 - Future System Block Diagram

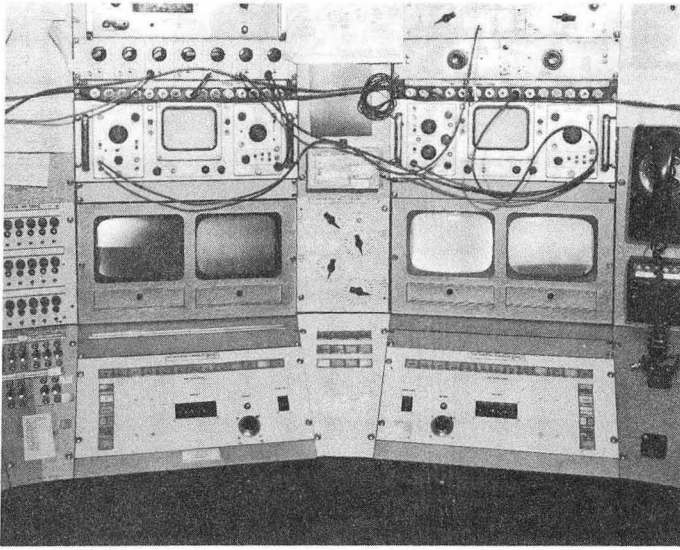

Fig. 5 - External Proton Beam Control Station

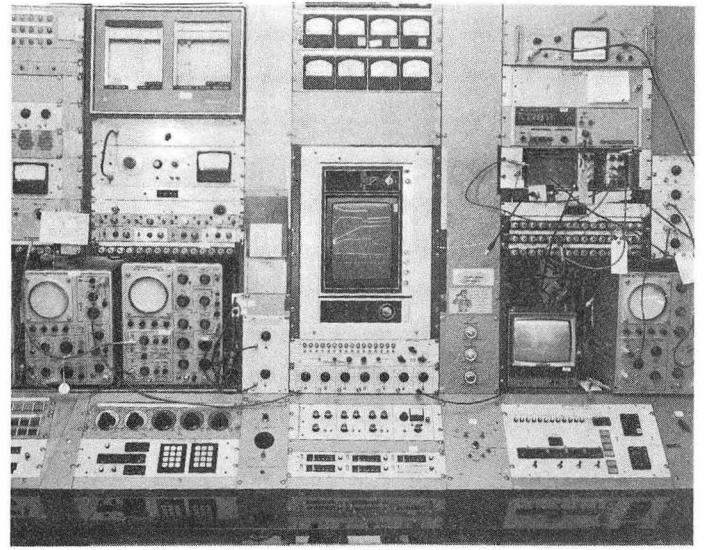

Fig. 6 - RF System Control Station

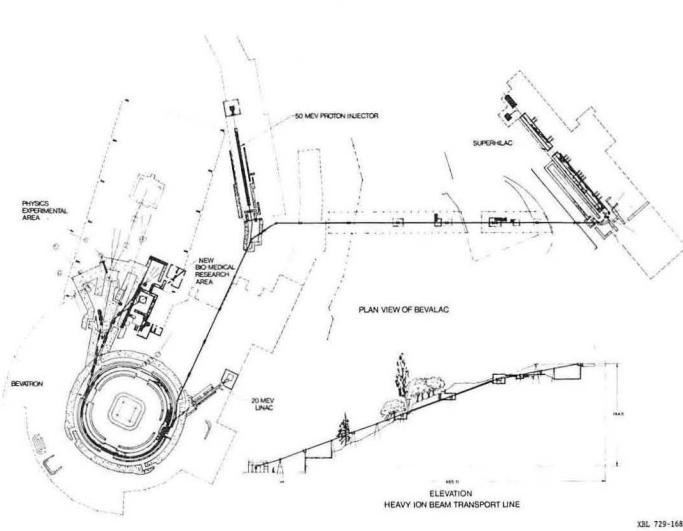

Fig. 7 - BEVALAC System

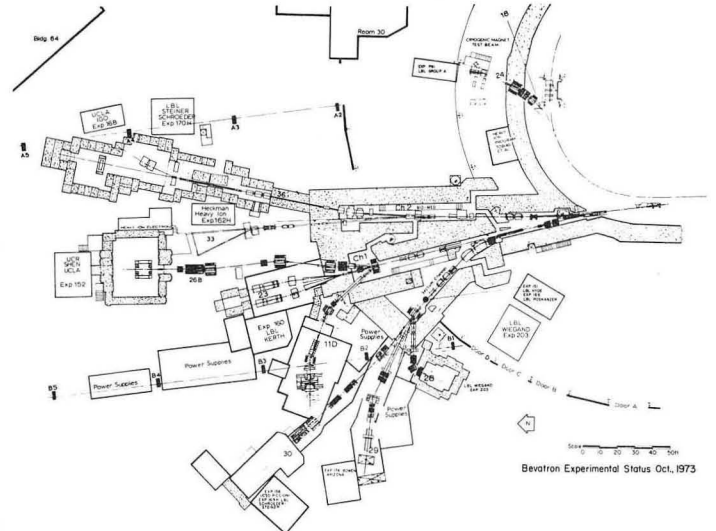

Fig. 8 - External Proton Beam

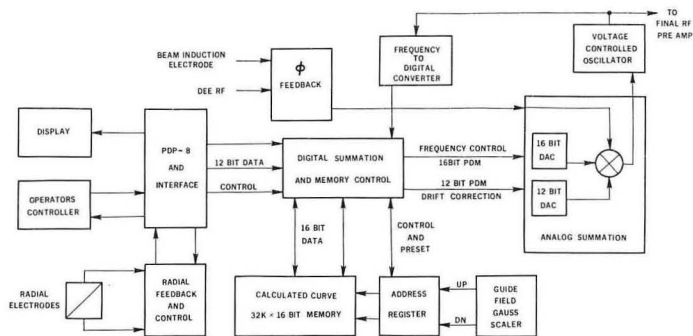

Fig. 9 - RF System Block System

LEGAL NOTICE

*This report was prepared as an account of work sponsored by the United States Government. Neither the United States nor the United States Atomic Energy Commission, nor any of their employees, nor any of their contractors, subcontractors, or their employees, makes any warranty, express or implied, or assumes any legal liability or responsibility for the accuracy, completeness or usefulness of any information, apparatus, product or process disclosed, or represents that its use would not infringe privately owned rights.*

TECHNICAL INFORMATION DIVISION  
LAWRENCE BERKELEY LABORATORY  
UNIVERSITY OF CALIFORNIA  
BERKELEY, CALIFORNIA 94720